

# StarDental

## Titan® SW Plus & K Plus

### Sonic Scaler

★ ★ ★ DO NOT USE FOR ORAL SURGERY ★ ★ ★

### Instruction Manual

EFFICIENCY IN DENTISTRY™

### Contents

Titan® SW Plus and K Plus Sonic Scalers – read all instructions carefully before using scaler.

- Specifications
- Titan SW Plus & Titan K Plus Installation
- Air Pressure and Water Flow Adjustments
- Tip Installation
- Tip Operation
- Cleaning
- Lubricating
- Sterilization
- Troubleshooting
- O-Rings & Rear Seal Replacement
- Rotor & Seal Rings Replacement
- Titan K Plus Muffler Replacement
- Titan K Plus Water Tube Gasket Replacement
- Replacement Part Numbers
- Warranty

Note: For sterilization instructions refer to the Sterilization Sheet, StarDental® Part #63395, and use it as a quick reference.

### Specifications (Nominal)

Titan K Plus 2/3-Line:	StarDental Part #263400	Titan SW Plus:	StarDental Part #263389
Titan K Plus 4-Line:	StarDental Part #263401		
Air Pressure:	40 psi (2.7 atmospheres)	Air Pressure:	40 psi (2.7 atmospheres)
	at the scaler		at the scaler
Air Flow:	1.5 SCFM (42.0 SLM)	Air Flow:	1.5 SCFM (42.0 SLM)
Water Flow:	25 cc/min. @ 15 psi	Water Flow:	25 cc/min. @ 15 psi
Length (with tip):	6.5 inches (16.5 cm)	Length (with tip):	7.56 inches (19.2 cm)
Weight:	2.0 ounces (56.7 grams)	Weight:	1.6 ounces (45.3 grams)

### Titan SW Plus & K Plus Installation

Note: Use softened and deionized water. Be sure filters operate efficiently. Before installing scaler, thoroughly purge both the dental unit air line and water line. Verify recommended filtration of 10 microns air and 25 microns water.

CAUTION: If delivery unit has oil/mist lubrication, detach and drain.

Push Titan SW Plus scaler onto swivel until it snaps into place.

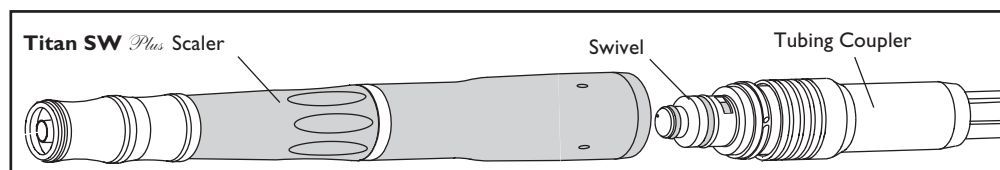

Connect the Titan K Plus by threading to the tubing coupler.

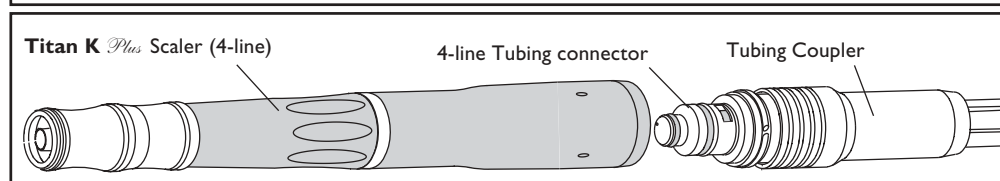

The Titan SW Plus requires a separate installation of either a 2/3-line swivel, StarDental Part #261550, or a 4-line swivel, StarDental Part #261547, depending on the handpiece tubing configuration.

1. Grasp the swivel in front of the bearing assembly between the thumb and index finger as shown.
2. Slide tubing coupler back until the end of the ISO connector is exposed. Hold in hand as shown with fingers securing the tubing.
3. Align and insert swivel tubes into the ISO connector holes.
4. While applying slight pressure to hold fittings in the connector holes, slide coupler forward and engage threads. Continue threading clockwise until hand tight against the swivel.

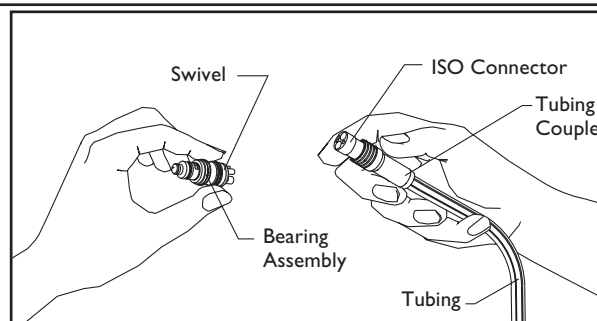

5. Using the disconnect wrench, StarDental Part #203048, hold the swivel stationary while tightening the tubing coupler until snug. Be sure to turn tubing coupler, not swivel. Do not overtighten.
6. Snap scaler onto swivel.

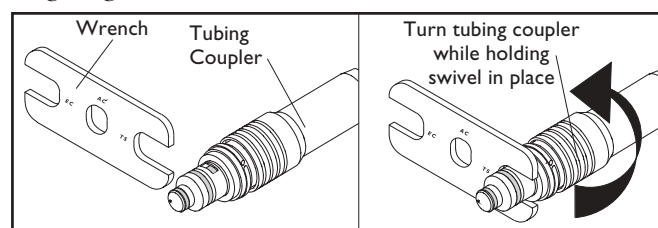

Note: To disconnect scaler from swivel, grasp scaler firmly with one hand and pull tubing coupler with the other. Do not pull on tubing. Swivel remains with tubing as shown.

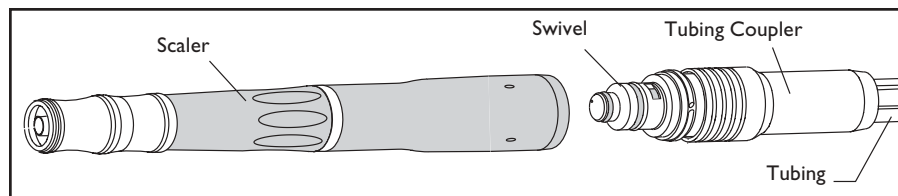

Note: The swivel tubing connection joint may loosen over time, resulting in water leaks and/or loss of power. Check for tightness periodically.

### Air Pressure and Water Flow Adjustments

1. Thread the selected tip. With the scaler operating, rotate tip a 1/4 turn with fingers.
2. Mount 4/6-line pressure gauge, StarDental Part #262591, between the scaler and the air supply tubing for the Titan K Plus Scaler. Mount the pressure gauge between the swivel and air supply tubing for the Titan SW Plus Scaler. Snap scaler onto swivel.
3. Turn water OFF.
4. Fully depress foot control. Adjust air supply on delivery unit until gauge shows 40 psi, 2.72 kg/cm<sup>2</sup>.

Note: Do not exceed 40 psi. Patient sensitivity and tooth damage may result.

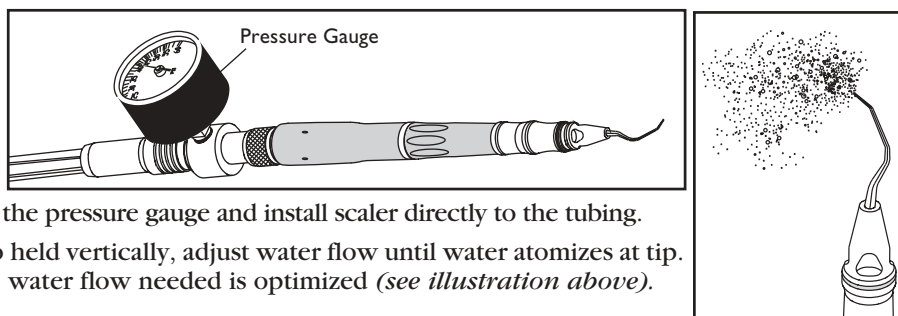

5. After adjustment, uncouple the pressure gauge and install scaler directly to the tubing.
6. With scaler running and tip held vertically, adjust water flow until water atomizes at tip. When water atomizes, the water flow needed is optimized (see illustration above).

### Tip Installation

CAUTION: To prevent damage to the scaler, do not tighten tips with the universal wrench. Use the universal wrench ONLY to remove tips. Use the wrench as illustrated.

Note: Do not sharpen or alter tips in any way.

1. Thread the selected tip onto the scaler with the scaler operating until it stops turning. Rotate slightly with fingers until tight.
2. When the procedure is complete and the scaler is no longer in use, remove the tip and cap it with the cover provided, StarDental Part #261358. This practice prevents injury to patient or staff.
3. To change tips, always loosen or tighten with the scaler running. The vibration makes changing tips easier.

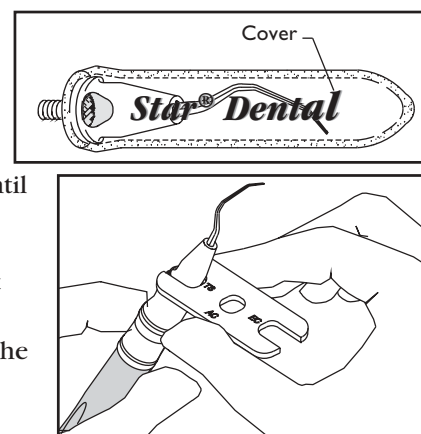

### Tip Operation

Remember:

- 1) Use the last 1/8" of tip
- 2) Use the edges of the tip, not the flats
- 3) Keep the tip moving in either of two motions as shown.

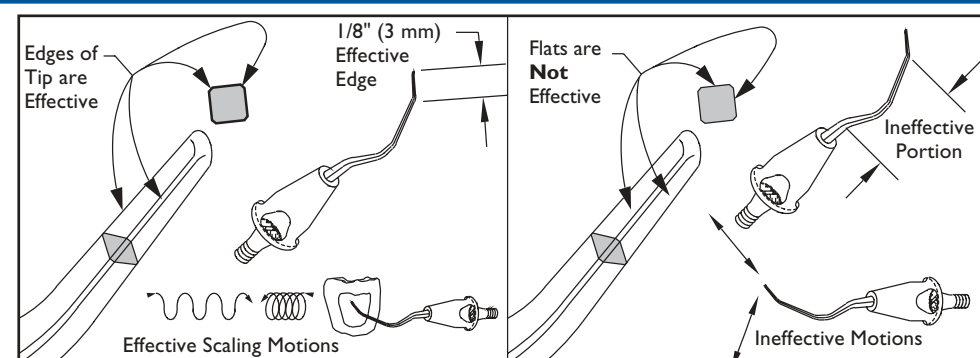

Operation of the Titan SW Plus and K Plus Sonic Scaler Tip is similar to that of an ultrasonic scaler. Follow these steps to minimize the risk of damage to restorations.

1. Always scale with tip at an angle to the restoration margin.
2. Use a "feather touch," one to two ounces applied pressure.
3. Move tip in a crosshatching, circular or wave fashion (see illustration).

WARNING: ALWAYS USE WATER.

Note: Normal use results in tip wear. Replace tips annually. Use the tip lengths indicated to determine more frequent replacement. Replace if shorter by .02" (1/2 mm) or more.

Use tips for subgingival scaling and fine access. Select a tip according to the following applications.

Universal - StarDental Part #261668  
• Use for all surfaces, medium and heavy calculus

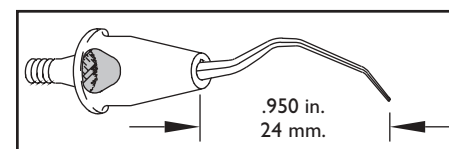

Sickle - StarDental Part #261667  
• Recommended for sensitive patients  
• Less energetic than the Universal Tip  
• Less suitable for deep root scaling

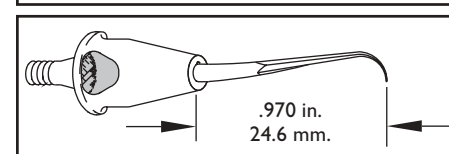

Perio - StarDental Part #261669  
Perio Left - StarDental Part #263397  
Perio Right - StarDental Part #263398

- Recommended for lingual supragingival scaling of mandibular incisors and deep local pockets
- Provides the same energy as the Universal Tip
- Use to break up heavy calculus deposits

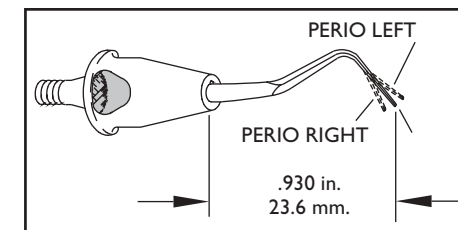

### Cleaning

#### CLEANING Tips

Clean tips weekly by running cleaning wire, StarDental Part #256719, through entire tip starting at opening in front.

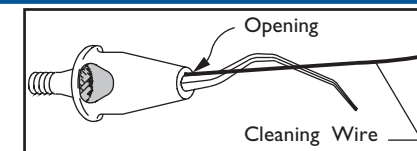

#### CLEANING Titan SW Plus or K Plus Water Tube

On a regular basis or if a water tube blockage occurs, remove the tip (and on the Titan SW Plus also disconnect from swivel). Push the cleaning wire through the internal water tube using needle nose pliers at the front on both the Titan SW Plus and K Plus as shown. Push small lengths of 3 to 4 mm at a time until the wire emerges at the opposite end. Pull wire completely out.

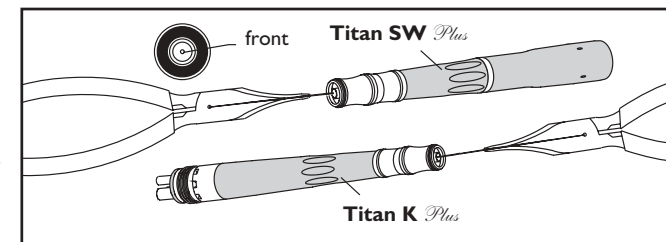

#### CLEANING the Swivel

Note: To insure peak performance and proper functioning of scaler, clean swivel and mating components daily or as needed. Do not attempt to disassemble swivel.

1. Disconnect swivel from scaler and tubing. Depress foot control; verify that water exits tubing.
2. Connect swivel to tubing. Depress foot control; if almost no water exits front of swivel, clean as follows.
3. Detach swivel from tubing and find water tube.
4. Insert cleaning wire, StarDental Part #256719, into water tube. When wire will not insert, move wire back and forth to loosen debris at blockage.
5. Remove wire and apply a blast of air into water tube with syringe air.

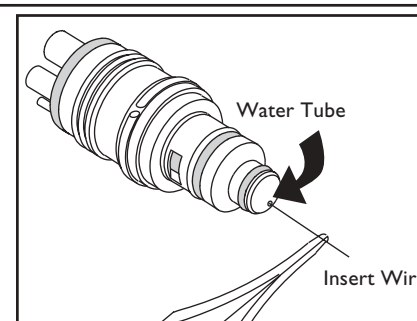

#### CLEANING Mating Parts of the Swivel

To optimize operation of the swivel, disconnect mechanism and swab all internal surfaces of scaler with a cotton swab soaked in isopropyl alcohol until clean. Dry using syringe air.

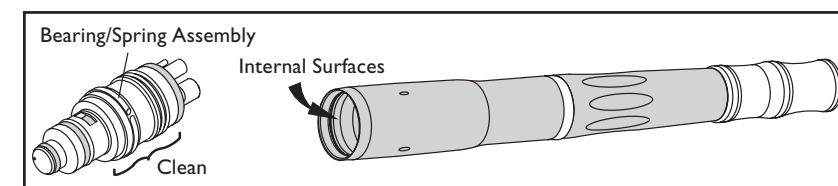

Clean area in the bearing/spring assembly at rear of swivel using isopropyl alcohol and a toothbrush. Dry using syringe air.

### Lubricating

#### LUBRICATING Titan SW Plus and Titan K Plus

Always lubricate scaler prior to each autoclave sterilization with DentaLube for Titan Sonic Scalers, StarDental Part #261818.

1. To remove Titan K Plus Scaler from tubing: Unthread from the tubing coupler. Disconnect the Titan SW Plus from the swivel by grasping the scaler with one hand, pull coupler with other hand. Do not pull on the tubing. When separated, the swivel remains with the tubing coupler.
2. Find drive air on Titan K Plus or notched hole inside of Titan SW Plus (see illustration).
3. Insert lubricator tip firmly into nozzle. Spray a short burst of DentaLube for Titan Sonic Scalers into the Titan K Plus drive air tube or in a notched hole of the Titan SW Plus.
4. Thread tubing coupler onto the Titan K Plus or snap Titan SW Plus onto swivel; attach tip.

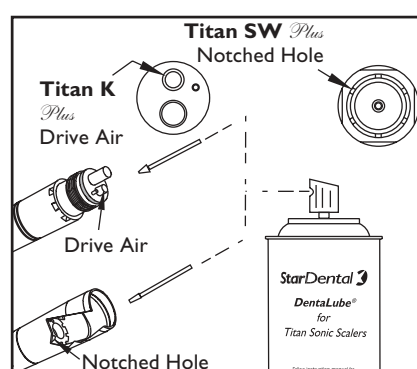

Note: Never run scaler without the tip in place.

5. Run scaler for 20 seconds to circulate lubricant; remove the tip.
6. Steam sterilize, see Sterilization.

### Sterilization

1. Wear puncture resistant gloves to prepare scaler for sterilization.
2. After each patient, flush air and water by running scaler.
3. Remove tip from scaler.
4. Lube scaler as described in Cleaning & Lubricating.
5. Attach Titan K Plus to tubing by turning coupler clockwise. Attach Titan SW Plus by snapping onto swivel.
6. Attach tip to scaler. Never run scaler without tip in place.
7. Run scaler 20 seconds to expel excess lube; remove tip.
8. Detach scaler by reversing Step 5.
9. Clean all external surfaces using a small toothbrush with isopropyl alcohol.
10. Dry thoroughly.
11. Place scaler in a sterilization bag; use paper or paper/plastic bags only. Follow the sterilization guidelines as stated by the manufacturer of your sterilizer.
12. Remove scaler from sterilizer after drying cycle ends and allow to cool in bag.

## Sterilization (cont.)

The scaler must be cleaned and sterilized between patient use.

A **wrapped** scaler should be steam sterilized at 132° C for a minimum of 10 minutes or at 121° C for a minimum of 50 minutes. Do not exceed 135° C.

An **unwrapped** scaler should be steam sterilized at 132° C for a minimum of 8 minutes or at 121° C for a minimum of 30 minutes. Do not exceed 135° C.

**Note:** An unwrapped scaler needs to be used immediately or sterility is not maintained.

Do not exceed the sterilizer manufacturer's guidelines for load capacity.

**CAUTION:** Use steam sterilization exclusively for complete sterility. Never dry heat sterilize, ultrasonically clean, expose to chemical disinfection or cold sterilization by:

- Immersion techniques
- Surface wipes, hand soaps or detergents
- Surface spray
- Handpiece pouches that contain disinfectants.

## Troubleshooting

<b>Problem:</b>	<b>NO VIBRATION OR NOISE</b>
<b>Cause:</b>	No air
<b>Correction:</b>	Check pressure at compressor and delivery unit.
<b>Cause:</b>	Blocked air line
<b>Correction:</b>	Check for air at tubing coupler.
<b>Cause:</b>	Control unit not functioning
<b>Correction:</b>	Check operation of handpieces and syringe. If needed, remove tubing from control block and check for blockage of drive air tubing.
<b>Problem:</b>	<b>LOW VIBRATION LEVEL OR LOW POWER</b>
<b>Cause:</b>	Low air pressure
<b>Correction:</b>	Check for full depression of foot control, unit pressure and compressor output. Check pressure at scaler with air gauge 4/6-line, <b>StarDental</b> ® Part #262591.
<b>Cause:</b>	Tip loose
<b>Correction:</b>	Finger tighten, do not tighten tip with wrench. Refer to <i>Tip Installation</i> .
<b>Cause:</b>	Dirty rotor
<b>Correction:</b>	Lubricate with DentaLube for Titan® Sonic Scalers, <b>StarDental</b> Part #261818.
<b>Cause:</b>	Tip touches handle
<b>Correction:</b>	Check all handle joints for tightness. If OK, return scaler to factory for repair.
<b>Cause:</b>	Rotor seal rings out of alignment
<b>Correction:</b>	Remove handle, relocate rotor seal rings in shallow grooves. Carefully thread handle on to prevent damage to seal rings.
<b>Cause:</b>	Broken or worn tip
<b>Correction:</b>	Refer to <i>Tip Operation</i> for tip lengths. Replace if shorter by .02" (1/2mm) or more.
<b>Cause:</b>	Rotor broken
<b>Correction:</b>	Remove handle; replace rotor. Refer to <i>Rotor &amp; Seal Rings Replacement</i> .
<b>Cause:</b>	Broken rear suspension (very high air noise, low pitch)
<b>Correction:</b>	Return scaler to dealer or factory for repair.
<b>Cause:</b>	Defective swivel, O-rings and/or seal
<b>Correction:</b>	Refer to <i>O-Rings &amp; Rear Seal Replacement</i> .
<b>Problem:</b>	<b>BLOCKED MUFFLER</b>
<b>Cause:</b>	Replace muffler
<b>Correction:</b>	Refer to <i>Muffler Replacement</i> .
<b>Problem:</b>	<b>UNABLE TO DETACH SWIVEL FROM SCALER</b>
<b>Cause:</b>	Lack of maintenance
<b>Correction:</b>	Spray a short burst of DentaLube for Titan Sonic Scalers into swivel-tubing connector area; rotate swivel to circulate lube. Disengage handpiece. Contact dealer if unable to disengage swivel. To prevent reoccurrence, refer to <i>Cleaning</i> .
<b>Problem:</b>	<b>NO WATER</b>
<b>Cause:</b>	Water off
<b>Correction:</b>	Check dental unit controls and inlet supply.
<b>Cause:</b>	Tip blocked
<b>Correction:</b>	Remove tip, check flow. If tip blocked, refer to <i>Cleaning Tip</i> .
<b>Cause:</b>	Water tube blocked or swivel clogged
<b>Correction:</b>	Clean scaler or swivel water tube. Refer to <i>Cleaning Water Tube</i> .
<b>Cause:</b>	Worn swivel O-rings or seal
<b>Correction:</b>	Replace O-rings and/or seal. Refer to <i>O-Rings &amp; Rear Seal Replacement</i> .
<b>Problem:</b>	<b>WATER LEAKS AT REAR</b>
<b>Cause:</b>	Rear seal
<b>Correction:</b>	Tighten tubing coupler. If leak persists, refer to <i>O-Rings &amp; Rear Seal Replacement</i> .
<b>Problem:</b>	<b>WATER LEAKS BETWEEN TIP AND HANDLE</b>
<b>Cause:</b>	Tip shaft seat dirty
<b>Correction:</b>	Clean shaft end recess with cotton swab soaked in isopropyl alcohol. Clean conical tip seat.
<b>Problem:</b>	<b>AIR LEAK INTO WATER STREAM</b>
<b>Cause:</b>	Rear seal leaks
<b>Correction:</b>	Tighten tubing coupling. If leak persists, refer to <i>O-Rings &amp; Rear Seal Replacement</i> .
<b>Problem:</b>	<b>WATER DOES NOT ATOMIZE</b>
<b>Cause:</b>	Front suspension O-rings
<b>Correction:</b>	Replace front suspension, refer to <i>O-Rings &amp; Rear Seal Replacement</i> .

**Problem:** AUDIBLE IRREGULARITY, CHANGE IN PITCH OR NOISE

**Cause:** Tip loose

**Correction:** Finger tighten, do not tighten tip with wrench. Refer to *Tip Installation*.

**Cause:** Rotor broken

**Correction:** Remove handle, replace rotor. Refer to *Rotor & Seal Rings Replacement*.

**Cause:** Rear suspension broken

**Correction:** Return to factory through authorized dealer for repair.

**Note:** If any problem persists, contact dealer for further assistance or contact **StarDental** Customer Service at 1-866-DTE-INFO.

## O-Rings & Rear Seal Replacement

**Swivel O-Rings:** Periodically replace the swivel O-rings, **StarDental** Part #259884.

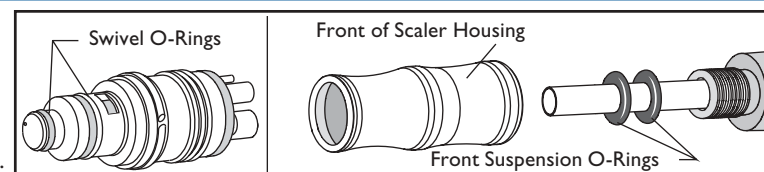

**Front Suspension O-Rings:** After two years, front suspension O-rings relax resulting in play between shaft and handle.

**WARNING:** Never remove scaler housing with tip assembled to the scaler.

1. Unthread the front of the scaler housing to expose the front suspension O-rings.
2. Remove the two *old* O-rings and install the replacement O-rings, **StarDental** Part #256718.
3. Rethread front of scaler housing to original position.

**Titan K/SW Plus & Rear Seal Swivel O-Rings**

Seals wear with repeated use. Replace rear seals annually or as needed. On either the 2/3-line swivel or **Titan K Plus** 2/3-line scaler, replace the 2/3-line rear seal with **StarDental** Part #203103. On either the 4-line swivel or **Titan K Plus** 4-line scaler, replace seal with **StarDental** Part #202897.

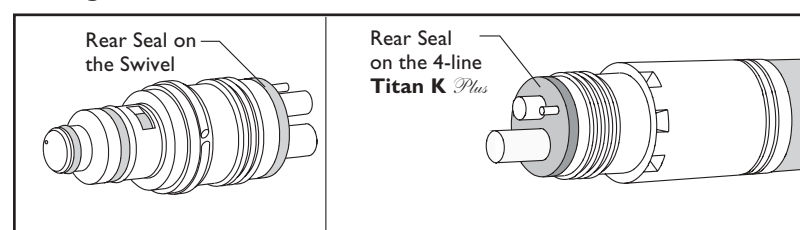

**2/3-line for Titan SW Plus and Titan K Plus**

1. Remove 2/3-line rear seal with an explorer.
2. Place new rear seal over drive air and water tubes.
3. Carefully push seal into place using a blunt instrument.

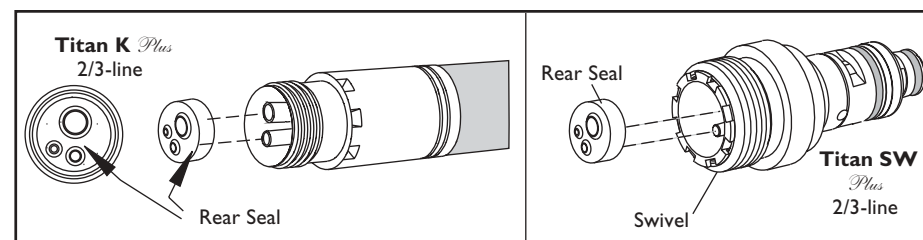

## Rotor Replacement

If rotor fails, scaler emits a low pitch 'burbling' sound and power reduces dramatically. Replace rotor and seals on **Titan SW Plus** or **Titan K Plus** with Rotor Spares Kit, **StarDental** Part #256715.

1. Remove tip.
2. Use clamp wrench provided to unthread handle from scaler housing exposing the shaft.
3. Slide off 2 pairs of seal rings and the *old* rotor.

**CAUTION:** Handle precision rotor with extra care.

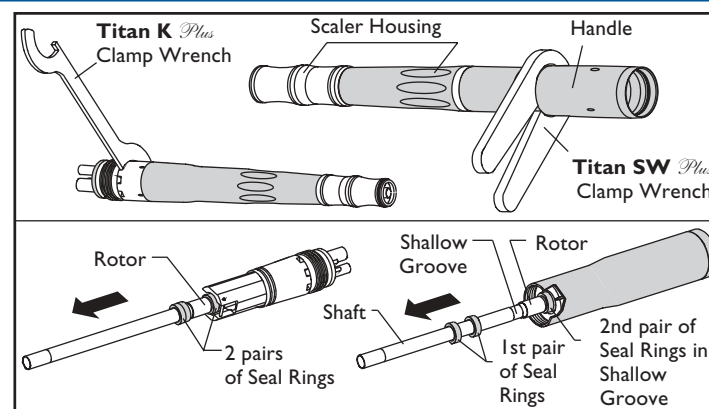

## Rotor & Seal Rings Replacement

**WARNING:** Never remove scaler housing with tip assembled to the scaler.

4. Clean shaft with a 2 x 2 gauze.
5. Slide *new* rotor and *new* seal rings onto shaft; verify both pair of rings are in both shallow grooves.
6. Thread scaler housing onto handle assembly. Take care to not catch seal rings with handle assembly.
7. Firmly tighten handle assembly to shaft.
8. Lubricate scaler and reconnect to handpiece tubing.
9. If power is inadequate after replacing rotor, reverse the rotor on the shaft as shown.

## Muffler Replacement

Replace the muffler on the **Titan K Plus** every two years with the muffler provided in **StarDental** Titan Spares Kit #256888, 2/3-line, or with **StarDental** Kit #256889, 4-line. The muffler is a length of knitted stainless steel wire mesh and installs in the rear of scaler to reduce noise and block dust and dirt.

1. Unthread handle.
2. Use an old dental instrument such as an explorer to pick out the *old* muffler.
3. Insert one end of the *new* muffler and systematically encircle the crevice as shown.

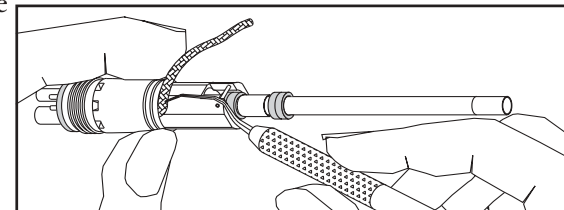

## Water Tube Gasket Replacement

Replace the washer gasket on the **Titan K Plus** water tube assembly annually with the gasket provided in the **StarDental** Spares Kit #256888 for the 2/3-line, or **StarDental** Spares Kit #256889 for the 4-line.

**CAUTION:** On 2/3-line use needle nose pliers *carefully* to prevent distortion of the air tube when removing water tube assembly.

1. Remove the water tube assembly. On 2/3-line model, remove retaining ring with an old dental instrument such as an explorer. Gently tug on the air tube with needle nose pliers to remove water tube assembly. Retaining ring pops out when removing assembly. *Take care not to lose retaining ring.*
2. Slide *old* gasket off water tube.
3. Slide on *new* gasket and seat in place.
4. Insert water tube into handle, rotate slowly between thumb and forefinger to locate internal water tube assembly. Push lightly to fully seat tube.

**Note:** On 2/3-line: reinstall retaining ring. Then assemble rear seal over tubes and retaining ring.

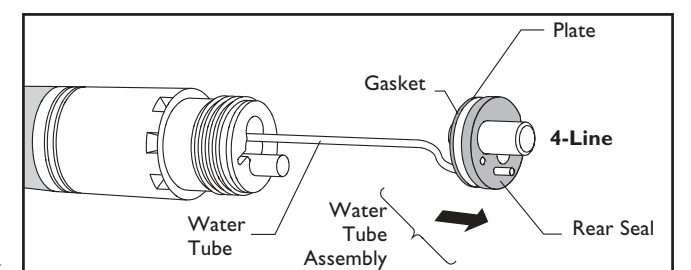
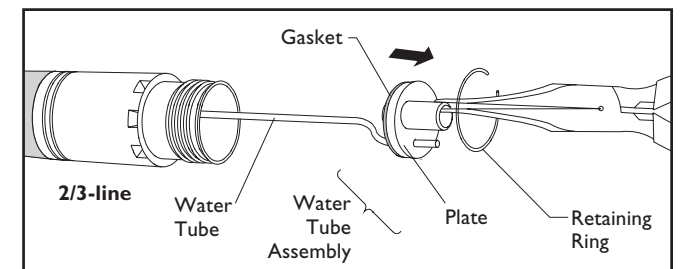

## Replacement Part Numbers

Always insist on **StarDental** parts for best performance.

Description	Item Number
Universal Tip (Plastic Cover Included) .....	261668
Sickle Tip (Plastic Cover Included) .....	261667
Perio Tip (Plastic Cover Included) .....	261669
Perio Left Tip (Plastic Cover Included) .....	263397
Perio Right Tip (Plastic Cover Included) .....	263398
Tip, Plastic Cover .....	261358
<b>Titan SW Plus</b> , 4-line Spares Kit (Includes 2 Front suspension O-rings, 2 large & 2 small swivel O-Rings, 2 retaining rings, rear seal, 2 cleaning wires, clamp wrench, and disconnect wrench) .....	263389
<b>Titan K Plus</b> , 2/3-line Spares Kit (Includes 2 Front suspension O-rings, 2 washer gaskets, muffler, 2 retaining rings, 2 cleaning wires, clamp wrench, and disconnect wrench) .....	263400
<b>Titan K Plus</b> , 4-line Spares Kit (Includes 2 Front suspension O-rings, 2 washer gaskets, muffler, 2 cleaning wires, clamp wrench, and disconnect wrench) .....	263401
Sensi-Tip Kit .....	263485
Sensi-Tip Replacement Pkg. of 100 .....	263486
Sensi-Tip Holder .....	263487
Sensi-Tip Wrench .....	263488
Cleaning Wire .008 Gauge (Package of 2) .....	256719
Retaining Ring .....	261349
Exhaust Plug, <b>Titan K Plus</b> .....	261356
O-Rings - Swivel (2 large, 2 small) .....	259884
O-Rings - Front Suspension (Package of 2) .....	256718
Rotor Spares Kit (Rotor, 4 Seal Rings) .....	256715
Rear Seal, 2/3-line (Package of 3) .....	203103
Rear Seal, 4-line (Package of 3) .....	202897
Water Tube Assembly, Gasket, Retaining Ring, 2/3-line <b>Titan K Plus</b> .....	256454
Water Tube Assembly, Gasket, 4-line <b>Titan SW Plus</b> .....	260503
Water Tube Assembly, Gasket, 4-line <b>Titan K Plus</b> .....	256455
Water Seal Assembly .....	261707
DentaLube for Titan Sonic Scalers (8.0 fl.oz. Spray Can) .....	261818
Air Pressure Gauge (ISO, 4/6-line) .....	262591
Disconnect Wrench .....	203048



For new products, manuals and technical information, call 1-866-DTE-INFO or visit our web site @ [www.dentalez.com](http://www.dentalez.com).

### Limited Warranty

**StarDental**® Titan® SW Plus and K Plus Sonic Scalers are warranted against defects in material and workmanship (excluding rotor, O-rings, and scaling tips) for one year from date of purchase. This warranty is subject to the following conditions:

Handpieces, swivel and LubeFree Turbine with Autochuck must not be abused and must have been operated in accordance with procedures detailed in this manual.

Warranty covers manufacturing defects only and does not cover defects resulting from abuse, improper handling, cleaning care or maintenance, normal wear and tear, or nonobservance of operating, maintenance or installation instructions. Failure to use authorized parts or an authorized repair facility voids this warranty.

Liability is limited to repair or replacement of the defective product at our sole discretion. All other liabilities, in particular liability for damages, including, without limitation, consequential or incidental damages, are excluded.

THIS WARRANTY IS IN LIEU OF ALL OTHER WARRANTIES, EXPRESSED OR IMPLIED, INCLUDING ANY IMPLIED WARRANTIES OF MERCHANTABILITY OR FITNESS FOR A PARTICULAR PURPOSE. NO EMPLOYEE, REPRESENTATIVE OR DEALER IS AUTHORIZED TO CHANGE THIS WARRANTY IN ANY WAY OR TO GRANT ANY OTHER WARRANTY.



DentalEZ Dental Products (GB) Ltd.,  
Cleveland Way, Hemel Hempstead,  
HP2 7DY, ENGLAND  
063396D

Product complies  
with MDD 93/42/EEC

Division of DentalEZ Group  
Lancaster, PA 17601-5891 U.S.A.  
Printed in the U.S.A.  
©2003 DentalEZ Group